

# NATIONAL INDUSTRIES

**11531**

**SINGLE PARTITION**

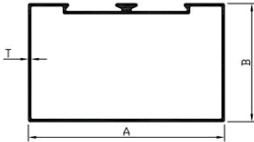

SEC.No.	A	B	T	Wt.(kg/Mtr.)	Wt.(kg/12')
11531	50.00	25.00	0.85	0.386	1.300-1.500
11532	50.00	25.00	1.50	0.683	2.500-2.700
11533	63.00	38.00	0.79	0.480	1.700-1.900
11534	63.00	38.00	0.90	0.534	1.900-2.100
11535	63.00	38.00	1.05	0.618	2.200-2.400
11536	63.00	38.00	1.15	0.669	2.400-2.600
11537	63.00	38.00	1.28	0.750	2.700-2.900
11538	63.00	38.00	1.50	0.870	3.200-3.500
11539	63.00	38.00	1.92	1.075	3.900-4.200
11540	63.00	38.00	3.00	1.642	6.000-6.500
11541	101.60	44.45	1.27	1.049	3.800-4.000
11542	101.60	44.45	1.60	1.300	4.780-5.200
11543	101.60	44.45	2.00	1.580	5.800-6.300
11544	101.60	44.45	3.00	2.350	8.600-9.100

**DOOR SECTION**

**11551**

**DOUBLE PARTITION**

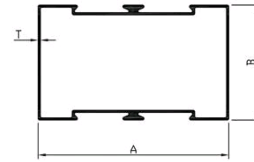

SEC.No.	A	B	T	Wt.(kg/Mtr.)	Wt.(kg/12')
11551	50.00	25.00	0.65	0.355	1.300-1.500
11552	50.00	25.00	1.40	0.683	2.500-2.700
11553	63.00	38.00	0.70	0.464	1.700-1.900
11554	63.00	38.00	0.83	0.547	1.900-2.100
11555	63.00	38.00	0.92	0.593	2.200-2.400
11556	63.00	38.00	1.00	0.685	2.400-2.600
11557	63.00	38.00	1.20	0.760	2.700-2.900
11558	63.00	38.00	1.50	0.875	3.200-3.500
11559	63.00	38.00	1.80	1.070	3.900-4.200
11560	63.00	38.00	3.00	1.720	6.300-6.700
11561	101.60	44.45	1.20	1.038	3.800-4.000
11562	101.60	44.45	1.60	1.311	4.800-5.200
11563	101.60	44.45	2.00	1.640	6.000-6.500
11564	101.60	44.45	3.00	2.400	8.800-9.300

**DOOR SECTION**

**11601**

**DOOR CENTRE**

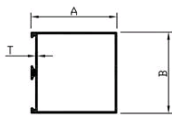

SEC.No.	A	B	T	Wt.(kg/Mtr.)	Wt.(kg/12')
11601	47.00	44.45	1.30	0.683	2.500-2.800
11602	47.00	44.45	1.45	0.765	2.800-3.100

**DOOR SECTION**

**11621**

**DOOR MIDDLE**

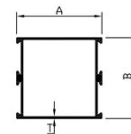

SEC.No.	A	B	T	Wt.(kg/Mtr.)	Wt.(kg/12')
11621	47.00	44.45	1.17	0.655	2.400-2.600
11622	47.00	44.45	1.50	0.882	3.200-3.500
11623	83.50	44.45	1.37	1.010	3.700-4.000
11624	83.50	44.45	2.00	1.475	5.400-5.800
11625	83.50	44.45	3.00	2.030	7.400-7.900

**DOOR SECTION**

# NATIONAL INDUSTRIES

## 11641

### DOOR TOP & DOOR BOTTOM

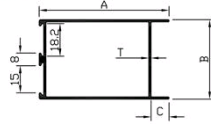

SEC.No.	A	B	C	T	Wt.(kg/Mtr.)	Wt.(kg/12')
11641	47.00	44.45	10.15	1.35	0.683	2.500-2.700
11642	47.00	44.45	10.15	2.00	0.983	3.600-4.000
11643	47.00	44.45	10.15	3.00	1.420	5.200-5.600
11644	85.00	44.45	10.00	1.50	1.055	3.800-4.100
11645	85.00	44.45	10.00	2.00	1.385	4.950-5.400
11646	85.00	44.45	10.00	3.00	2.070	7.500-8.000
11647	100.0	44.45	25.40	1.30	1.015	3.700-4.000
11648	114.30	44.45	25.40	1.36	1.201	4.400-4.800
11649	114.30	44.45	25.40	2.00	1.670	6.100-6.500
11650	114.30	44.45	25.40	3.00	2.486	9.100-9.500

### DOOR SECTION

## 11661

### DOOR VERTICAL

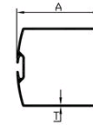

SEC.No.	A	B	T	Wt.(kg/Mtr.)	Wt.(kg/12')
11661	47.00	44.45	1.29	0.710	2.600-2.800
11662	47.00	44.45	1.41	0.765	2.800-3.000
11663	47.00	44.45	2.00	1.000	3.600-3.900
11664	85.00	44.45	1.40	1.038	3.800-4.200
11665	85.00	44.45	2.00	1.415	5.150-5.500
11666	85.00	44.45	3.00	2.040	7.400-7.900

### DOOR SECTION

## 11681

### GLAZING CLIP

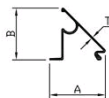

SEC.No.	A	B	T	Wt.(kg/Mtr.)	Wt.(kg/12')
11681	18.40	17.00	0.52	0.071	0.260-0.280
11682	18.40	17.00	0.60	0.076	0.280-0.320
11683	18.40	17.00	0.72	0.079	0.320-0.360
11684	18.40	17.00	0.82	0.092	0.360-0.420
11685	18.40	17.00	0.90	0.114	0.420-0.480

### DOOR SECTION

## 11691

### GLAZING PLATE

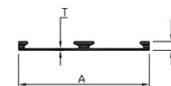

SEC.No.	A	B	T	Wt.(kg/Mtr.)	Wt.(kg/12')
11691	44.40	3.00	0.60	0.123	0.450-0.550
11692	44.40	3.00	1.10	0.163	0.600-0.800

### DOOR SECTION

# NATIONAL INDUSTRIES

## 11701

### LEG PARTITION

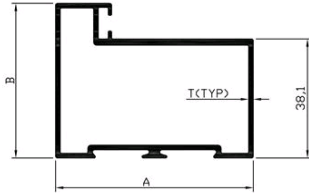

SEC.No.	A	B	T	Wt.(kg/Mtr.)	Wt.(kg/12')
11701	63.5	49.5	1.1	0.820	3.000-3.200
11702	63.5	49.5	1.3	1.052	3.400-3.750
11703	63.5	49.5	1.5	1.052	3.800-4.100

## DOOR SECTION

## 11710

### DOOR FRAME SEC.

SEC. NO:-11710

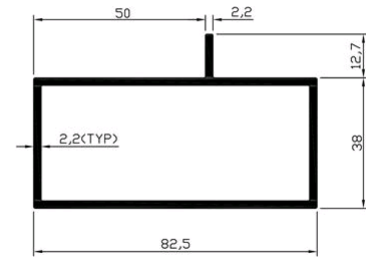

WEIGHT:- 5.300-5.600 kg/12'

## DOOR SECTION

## 11721

### DOOR SEC.

SEC. NO:-11721

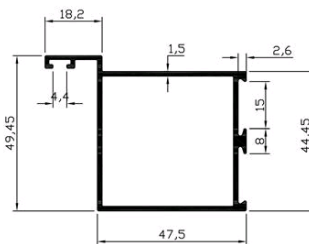

WEIGHT:- 2.900-3.100 kg/12'

## DOOR SECTION

## 11741

### SAMOSA SEC.

SEC. NO:-11741

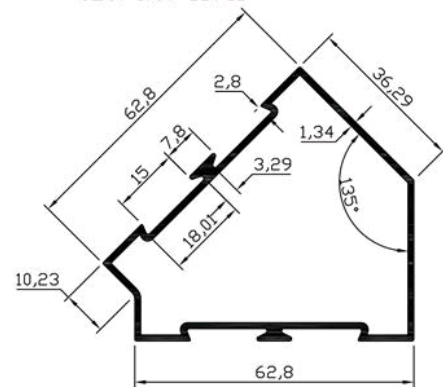

WEIGHT:- 3.300-3.500 kg/12'

## DOOR SECTION

# NATIONAL INDUSTRIES

**11751**

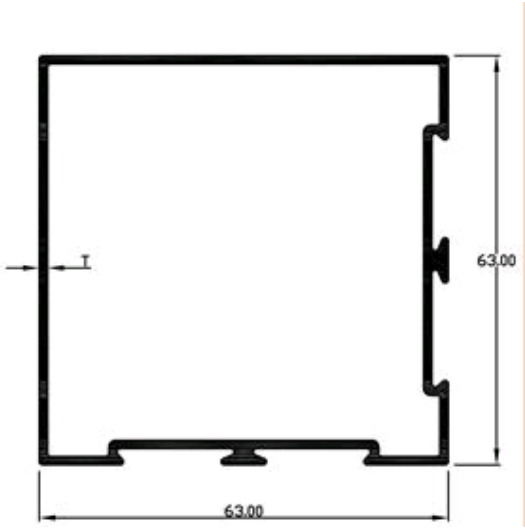

**DOOR SECTION**

**11761**

**FISHTYPE DOOR BOTTOM**

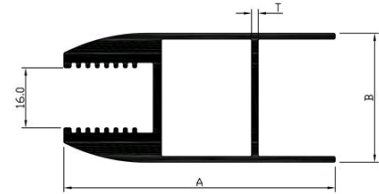

SEC.No.	A	B	T	Wt.(kg/Mtr.)	Wt.(kg/12')
11761	88.50	40.00	1.80	2.320	7.500-9.500
11762	88.50	40.00	2.70	2.595	9.500-10.500

**DOOR SECTION**

**13606**

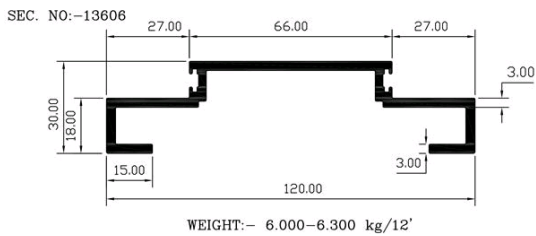

**DOOR SECTION**

**13611**

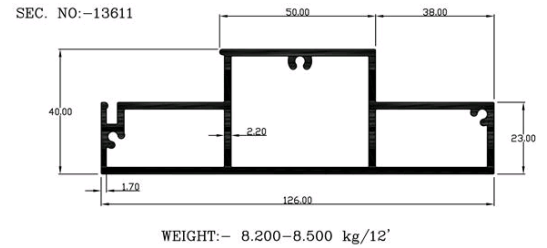

**DOOR SECTION**

# NATIONAL INDUSTRIES

14986

SEC. NO:-14986

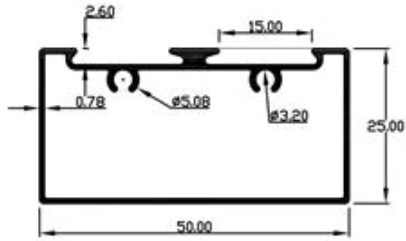

WEIGHT:- 1.470 kg/12'

DOOR SECTION

15196

SEC. NO:-15196

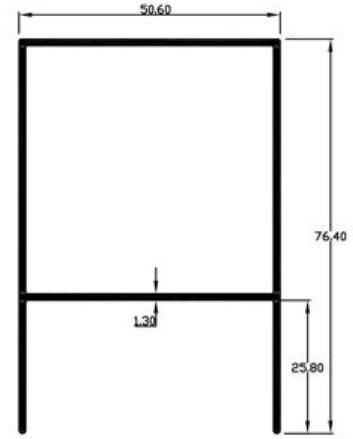

WEIGHT:- 3.194 kg/12'

DOOR SECTION

15931

SEC. NO:-15931

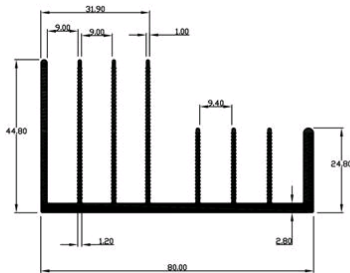

WEIGHT:- 5.900 kg/12'

DOOR SECTION

16037

SEC. NO:-16037

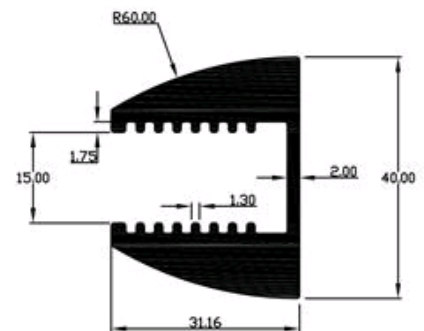

WEIGHT:- 5.638 kg/12'

DOOR SECTION

# NATIONAL INDUSTRIES

**16168**

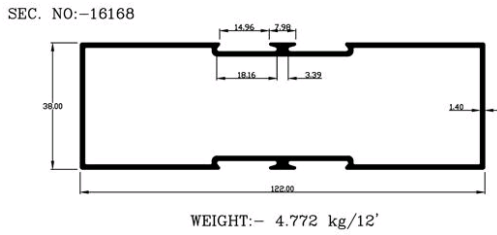

**DOOR SECTION**

**16254**

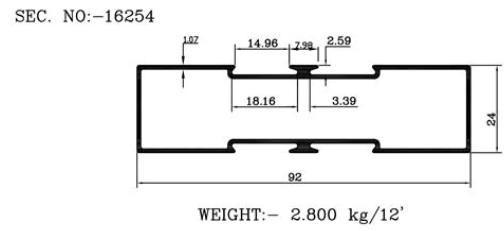

**DOOR SECTION**

**16273**

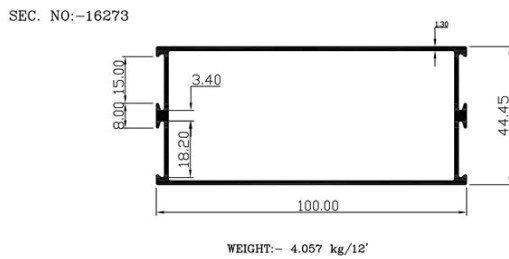

**DOOR SECTION**

**16287**

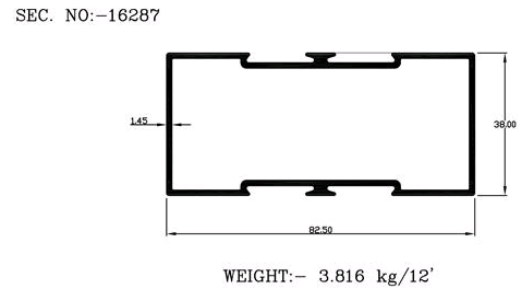

**DOOR SECTION**

# NATIONAL INDUSTRIES

## 16411

SEC. NO:--16411

IND-33

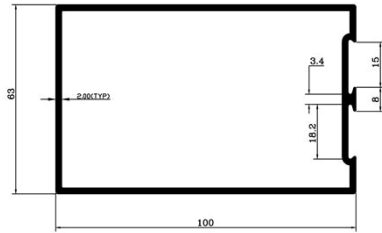

WEIGHT:- 6.514 kg/12'

## DOOR SECTION

## 16412

SEC. NO:--16412

IND-34

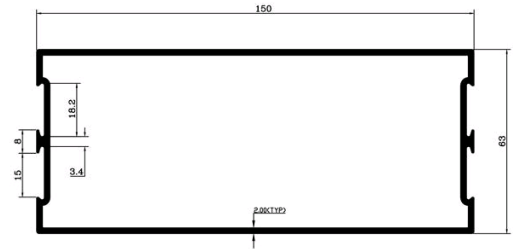

WEIGHT:- 8.725 kg/12'

## DOOR SECTION

## 16613

SEC. NO:--166613

VIP

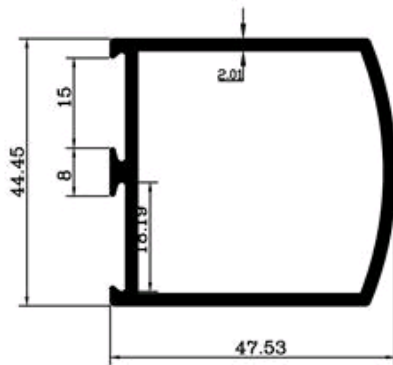

WEIGHT:- 3.523 kg/12'

## DOOR SECTION

## 16719

SEC. NO:--16719

IND

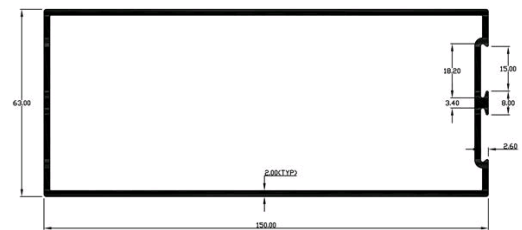

WEIGHT:- 8.500 kg/12'

## DOOR SECTION